

JC BORDELET

créateur d'harmonie

EVA - 992

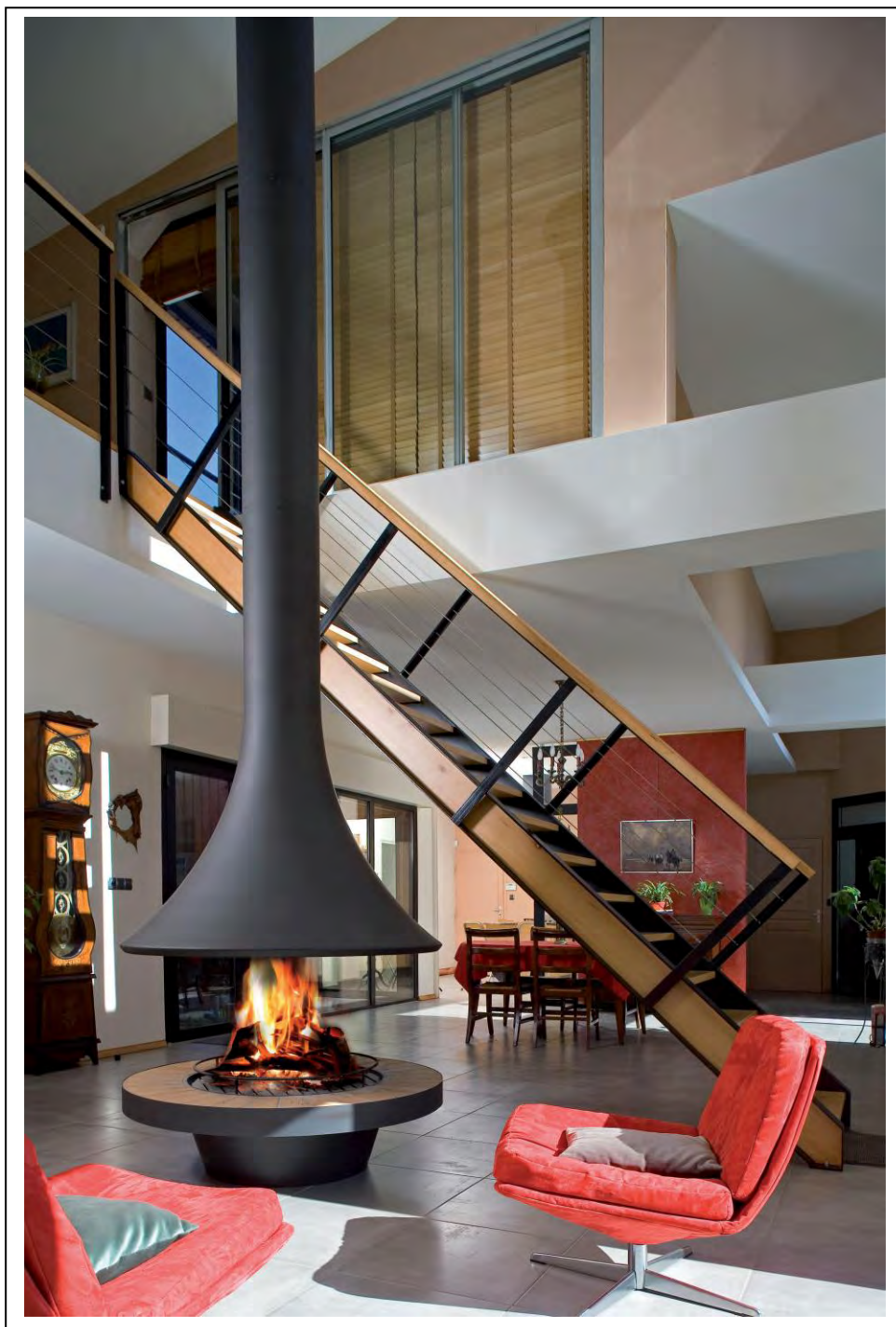



Certificate of Compliance

Certificate: 2637089

Master Contract: 256564

Project: 2637089

Date Issued: March 18, 2014

Issued to: JC BORDELET

ZI de Lherat
Randan, 63310
France
Attention: Jacques Aurand

The products listed below are eligible to bear the CSA Mark shown with adjacent indicators 'C' and 'US' for Canada and US or with adjacent indicator 'US' for US only or without either indicator for Canada only.



Joe Favot

Issued by: Joe Favot, P.Eng.

PRODUCTS

CLASS 6532 81 - SOLID FUEL BURNING EQUIPMENT - Residential Space Heaters -
Certified to US Standards

CLASS 6532 01 - SOLID FUEL BURNING EQUIPMENT - Residential Space Heaters

Decorative suspended wood fireplace, by Seguin

models:

- Léa 998 mural with glass door with 8 inch diameter chimney
- Léa 998 central with glass door with 8 inch diameter chimney
- Tatiana 997 mural with 10 inch diameter chimney
- Tatiana 997 central with 10 inch diameter chimney
- EVA 992 with glass door central with 10 inch diameter chimney
- EVA 992 with no glass door central with 10 inch diameter chimney
- EVA 992 with glass door mural with 10 inch diameter chimney
- EVA 992 with no glass door mural with 10 inch diameter chimney

APPLICABLE REQUIREMENTS



Certificate: 2637089

Master Contract: 256564

Project: 2637089

Date Issued: March 18, 2014

ULC S-610 M87 - Standard for factory-built fireplaces

UL 127, 9th edition - Factory-built fireplaces

MIS A L'ESSAIS SELON: ULC S610 M87
TESTED TO: AOUT/AUGUST 2013

FOYER PREFABRIQUE HOMOLOGUE
LISTED FACTORY BUILT-FIREPLACE
MODELE / MODELS : LEA 998
EVA 992
TATIANA 997

SERIAL # :



JC BORDELET

63300 RANDAN FRANCE



DÉGAGEMENTS MINIMAUX AUX MATÉRIAUX COMBUSTIBLES
MINIMUM CLEARANCES TO COMBUSTIBLE MATERIALS



MUR LATÉRAL : 1.21M (48")

SIDEWALL : 1.21M (48")

MUR ARRIÈRE : PROTECTION MURALE
BORDELET OU 0.46M (18")

BACKWALL : BORDELET WALL
PROTECTION OR 0.46M (18")

PLAFOND : HAUTEUR MIN. 2.43M (96")
LEA, EVA, TATIANA

CEILING : MIN. HEIGHT 2.43M (96")
LEA, EVA, TATIANA

UNE PLAQUE DE FOYER INCOMBUSTIBLE DOIT ETRE INSTALLEE A L'AVANT DU FOYER EXCEDANT DE 508MM (20") A L'AVANT ET 305MM (12") DES COTES DE L'OUVERTURE DES PORTES.
UTILISER SEULEMENT AVEC LES CHEMINÉES HOMOLOGUÉES (UL 103HT & ULCS-629 DE MARQUE : CHEMINÉE SÉCURITE, ICC, SELKIRK, SIMPSON) DE DIAMETRE 203MM (8") POUR LE MODELE LEA 998 ET DE DIAMETRE 254MM (10") POUR LES MODELES TATIANA 997 ET EVA 992
LES COMPOSANTES UTILISEES AVEC LE FOYER DOIVENT ETRE HOMOLOGUEES CSA.
REMPPLACER TOUT VERRE BRISE AVEC DU VERRE VITROCERAMIQUE DE 4mm(5/32") FOURNI EXCLUSIVEMENT PAR LE FABRICANT JC BORDELET

POUR UNE UTILISATION SECURITAIRE, INSTALLER ET OPERER CONFORMEMENT AUX INSTRUCTIONS DU FABRICANT POUR UNE UTILISATION AVEC BOIS SEULEMENT NE PAS UTILISER D'AUTRES COMBUSTIBLES.
OUVRIR LE REGISTRE DU TUYAU DE FUMEE AVANT D'OUVRIR LES PORTES POUR L'AVITAILLEMENT ET LE RAVITAILLEMENT NE PAS SURALIMENTER LE FOYER EN BOIS POUR EVITER LA SURCHAUFFE.

LORSQUE LE FOYER EST POURVU DE PORTES, OPERER AVEC LES PORTES COMPLETEMENT FERMEES.

AVERTISSEMENT : LORSQUE LE FOYER EST ALLUME, PREVOIR UN APPORT D'AIR SUFFISANT DANS LA PIECE, FAUTE DE QUOI ON RISQUE DE PRIVER LES AUTRES APPAREILS A COMBUSTION DE LEUR PART D'AIR COMBURANT.
POUR UNE UTILISATION SANS PORTE IL EST OBLIGATOIRE D'INSTALLER LE PARE-ÉTINCELLE VENDU PAR LE MANUFACTURIER.
LORSQUE DES BÛCHES DÉCORATIVES AU GAZ SONT INSTALLÉES DANS L'APAREIL, S'ASSURER QUE LE REGISTRE DU TUYAU DE FUMÉE SOIT MAINTENU OUVERT D'UNE FACON PERMANENTE.
NE PAS INSTALLER DE BÛCHES DÉCORATIVES AU GAZ DANS LES FOYERS LEA 998.
UTILISER SEULEMENT DES BÛCHES DÉCORATIVES AU GAZ HOMOLOGUE ANSI/ISA/AGA Z21.11.2
NE PAS FAIRE FONCTIONNER DES BÛCHES DÉCORATIVES DANS LE FOYER SANS LE TUYAU DE FUMÉE NI SANS UNE CHEMINÉE

A NON-COMBUSTIBLE HEARTH EXTENSION MUST BE INSTALLED AT FRONT OF UNIT EXTENDING 508MM (20") IN FRONT AND 305MM (12") TO SIDES OF DOOR OPENING.
FOR MODEL LEA 998 USE ONLY 203MM (8") DIAM. CHIMNEY
AND FOR MODELS TATIANA 997 & EVA992 USE ONLY 254MM (10") DIAM. CHIMNEY
LISTED (UL 103HT & ULC S-629 MODELS : SECURITY CHIMNEY, ICC, SELKIRK, SIMPSON) CHIMNEYS COMPONENTS USED WITH THE FIREPLACE MUST BE CSA LISTED

ONLY REPLACE BROKEN GLASS PANELS WITH 4MM (5/32") VITROCERAM GLASS PANELS AS SUPPLIED BY THE MAKER, JC BORDELET
INSTALL AND USE ONLY IN ACCORDANCE WITH THE MANUFACTURER'S INSTALLATION AND OPERATING INSTRUCTIONS.

FOR USE WITH WOOD ONLY DO NOT USE OTHER FUELS. DO NOT OVERFIRE UNIT
OPEN FLUE DAMPER BEFORE OPENING THE DOORS FOR FUELING AND REFUELING.

CAUTION : WHEN A FIRE IS BURNING IN THE FIREPLACE, A SUPPLY OF FRESH COMBUSTION AIR MUST BE SUPPLIED TO THE ROOM IN WHICH THE FIREPLACE IS LOCATED, FAILURE TO DO SO MAY STARVE OTHER FUEL BURNING APPLIANCES OF AN ADEQUATE AIR SUPPLY.
WHEN FIREPLACE IS PROVIDED WITH DOORS, ONLY OPERATE FIREPLACE WITH DOORS FULLY CLOSED.
WHEN FIREPLACE ISNT PROVIDED OF GLASS PANELS, A JC BORDELET FIRESCREEN MUST BE INSTALLED TO COMPLETELY SEAL OFF OPENING.

GAS LOG SHALL BE CERTIFIED FOR THE APPLICATION. WHEN INSTALLED, THE CHIMNEY DAMPER SHALL BE PERMANENTLY SECURED IN AN OPEN POSITION TO EFFECTIVELY VENT THE APPLIANCE.
DO NOT USE A FIREPLACE INSERT OR OTHER PRODUCT NOT SPECIFIED FOR USE IN LEA 998 FIREPLACE.
ONLY UNVENTED DECORATIVE GAS LOG SETS WICH HAVE BEEN FOUND TO COMPLY TO THE STANDARD FOR UNVENTED ROOM HEATERS, ANSI/IAS/AGA Z21.11.2 ARE T BE INSTALLED IN TATIANA AND EVA FIREPLACE.
DO NOT OPERATE AN UNVENTED GAS LOG SET IN THIS FIREPLACE WITH THE CHIMNEY REMOVED.

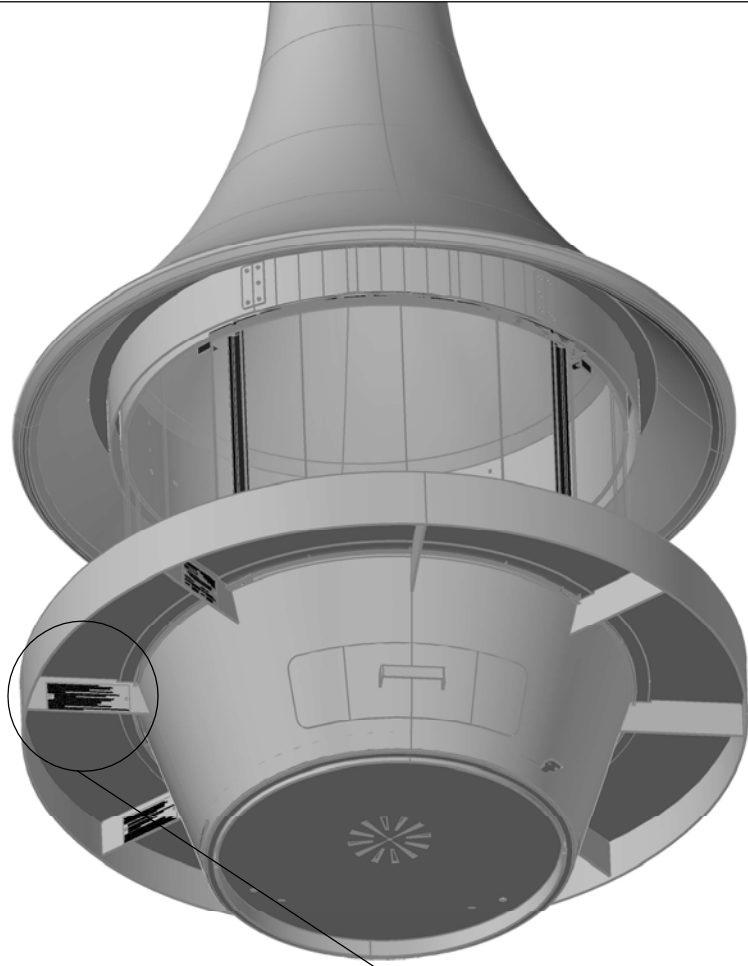

Plaques d'homologation
fixées par 6 vis M 5

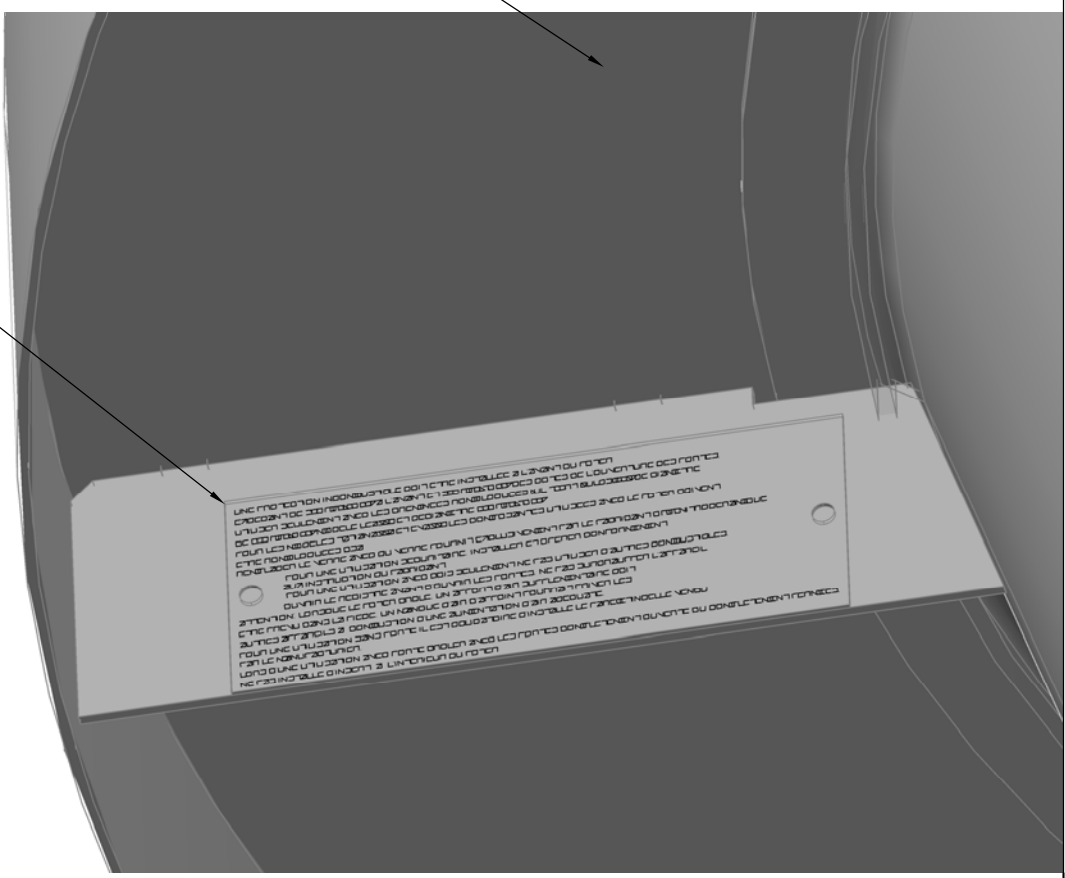

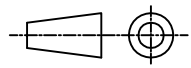
Matière:	Ep:	992	Date: 22/08/13	Indice: A
A4		Position plaque d'homologation Réf: 096	JC BORDELET créateur d'harmonie	

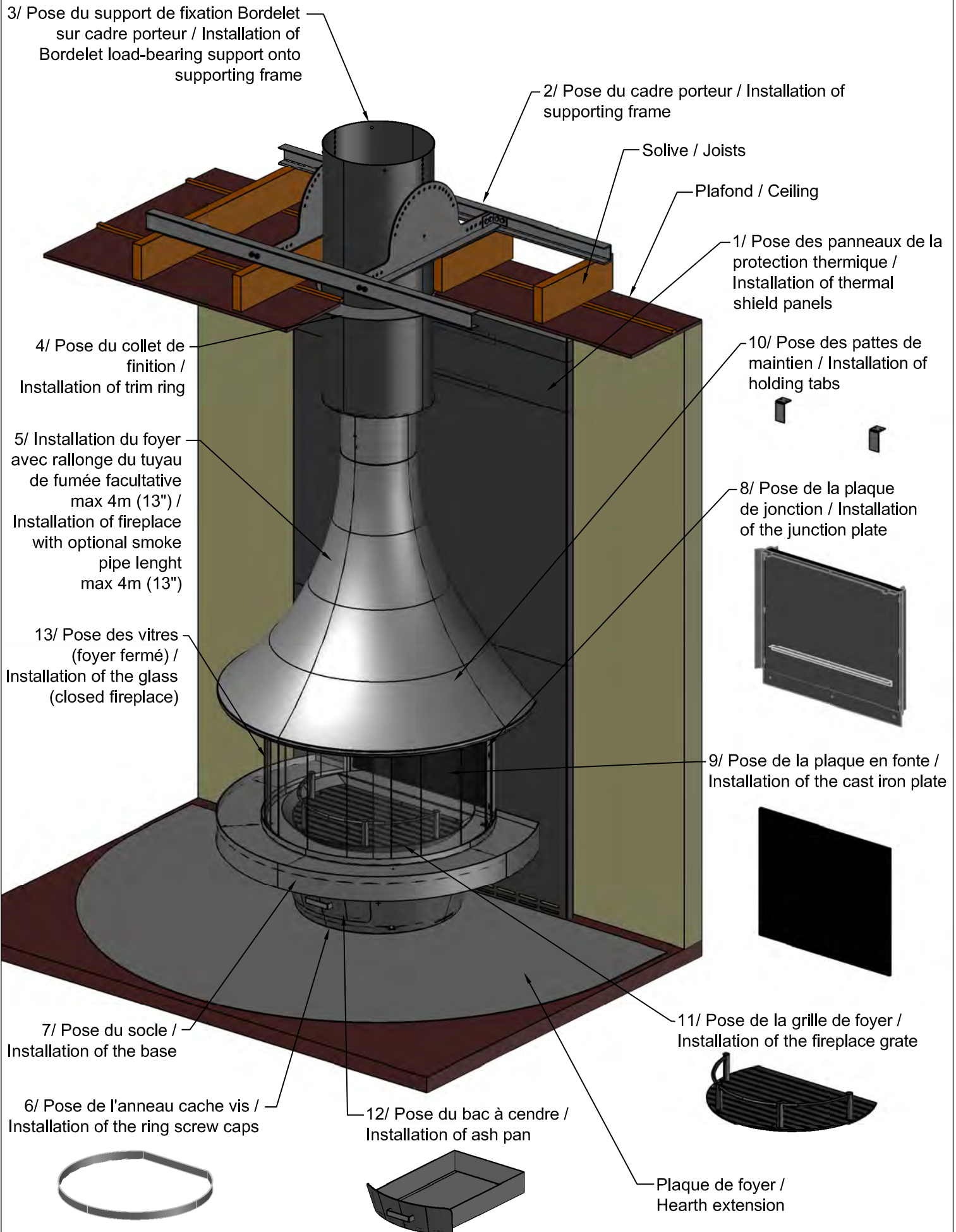

Matière:

Ep:

992 Pose cheminée

Date: 09/07/13

Indice: A

A4

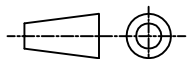

JC BORDELET
créateur d'harmonie

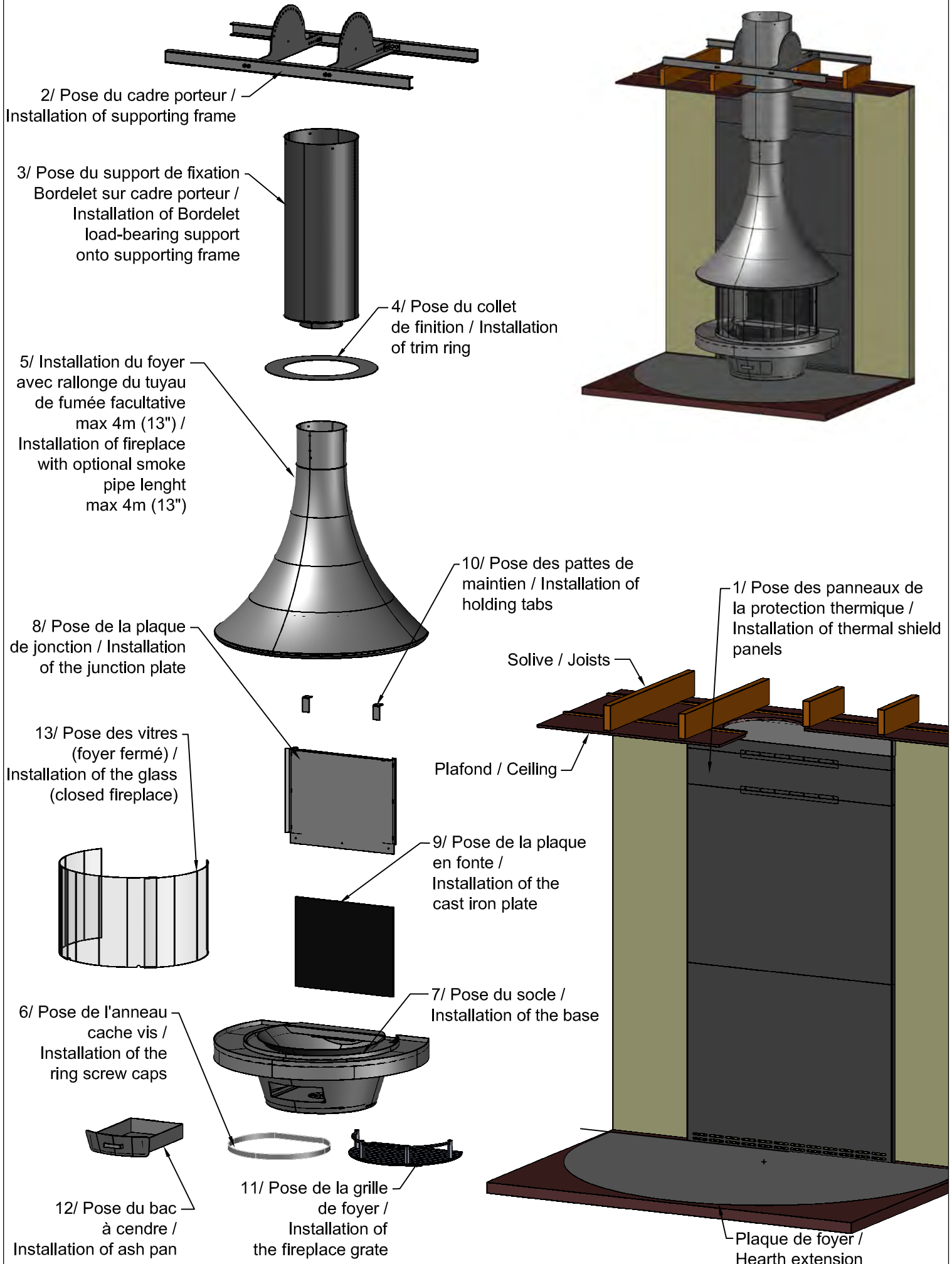

Matière:	Ep:	992 Pose cheminée éclaté	Date: 09/07/13	Indice: A
A4			JC BORDELET <small>créateur d'harmonie</small>	

1/ Pose du cadre porteur /
Installation of supporting frame

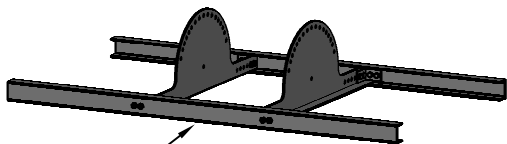

Solive / Joists

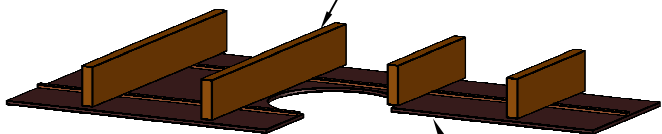

Plafond / Ceiling

2/ Pose du support de fixation
Bordelet sur cadre porteur /
Installation of Bordelet
load-bearing support
onto supporting frame

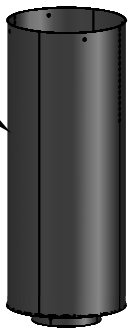

3/ Pose du collet
de finition / Installation
of trim ring



4/ Installation du foyer
avec rallonge du tuyau
de fumée facultative
max 4m (13") /
Installation of fireplace
with optional smoke
pipe lenght
max 4m (13")

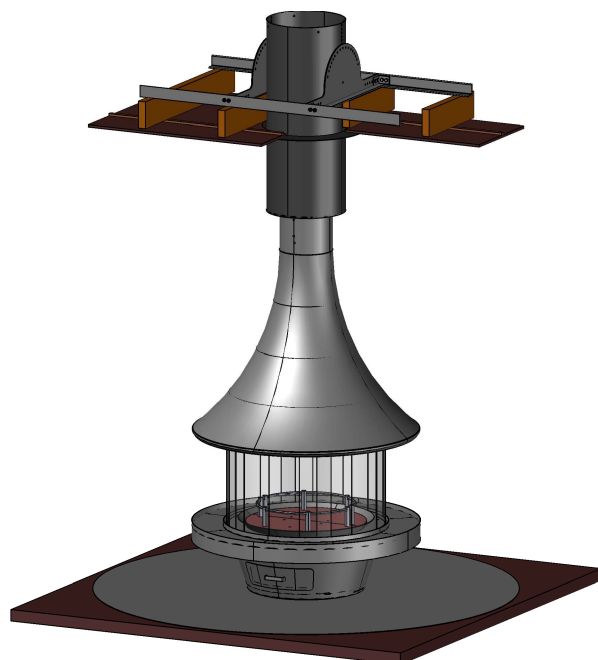
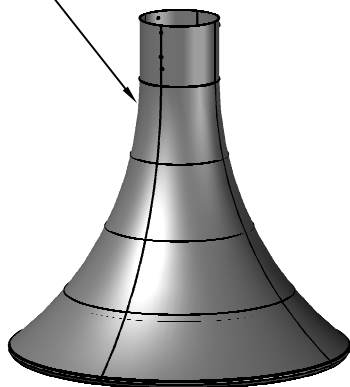

9/ Pose des vitres
(foyer fermé) /
Installation of the glass
(closed fireplace)

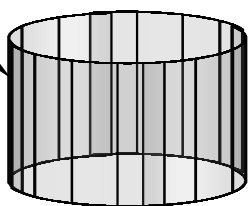

7/ Pose de la grille
de foyer /
Installation of
the fireplace grate



8/ Pose du bac
à cendre /
Installation of ash pan



6/ Pose du socle /
Installation of the base

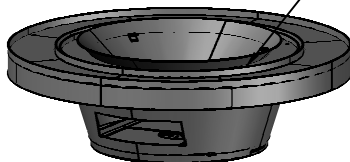

5/ Pose de l'anneau
cache vis /
Installation of the
ring screw caps



Plaque de foyer / Hearth extension

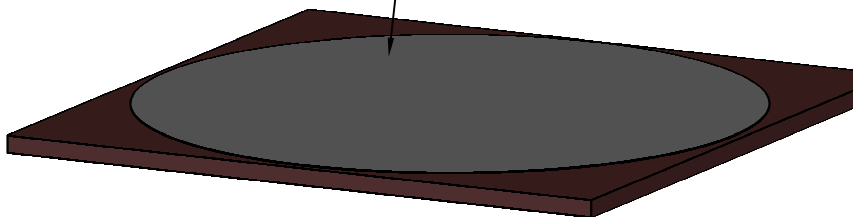

Matière:

Ep:

992 Pose cheminée
éclaté

Date: 09/07/13

Indice: A

A4

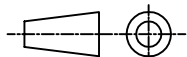

JC BORDELET
créateur d'harmonie

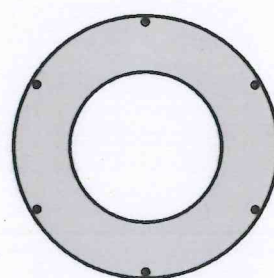
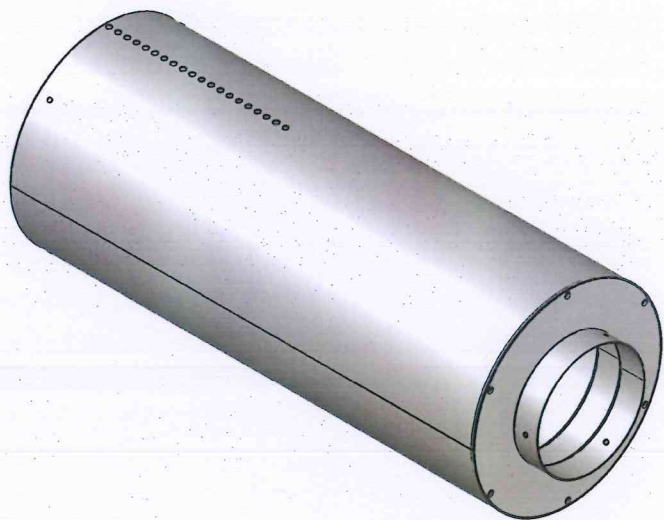

Matière: S235	Ep:	992 Caisson de fixation Réf: 076	Date: 03/10/13	Indice: A
A4			JC BORDELET créateur d'harmonie	

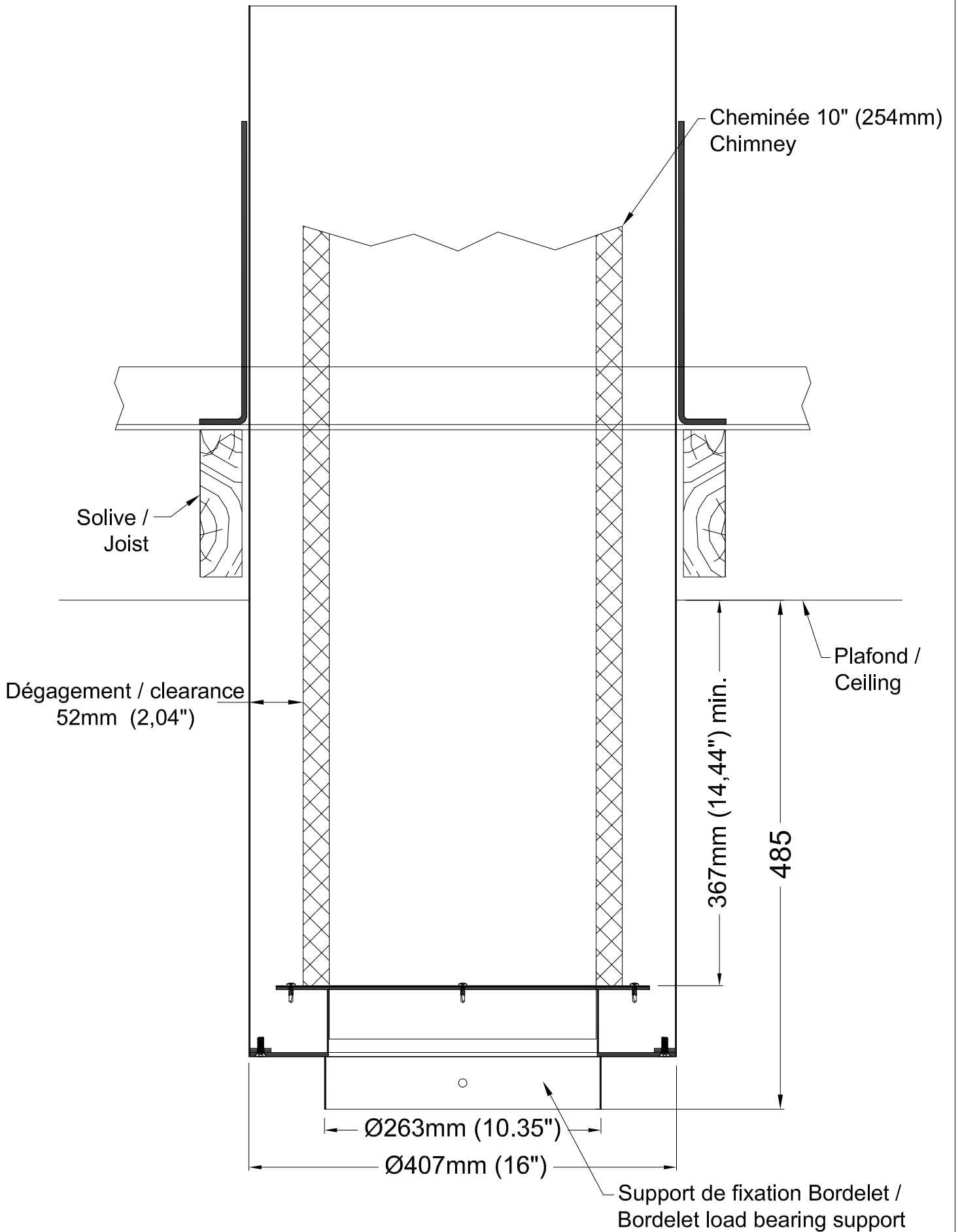

**Foyer EVA 992 - Fireplace - Raccord cheminée isolée -
254mm (10") - Connection to insulated chimney**

Cadre porteur fixé sur les solives /
Supporting frame fastened on the joists

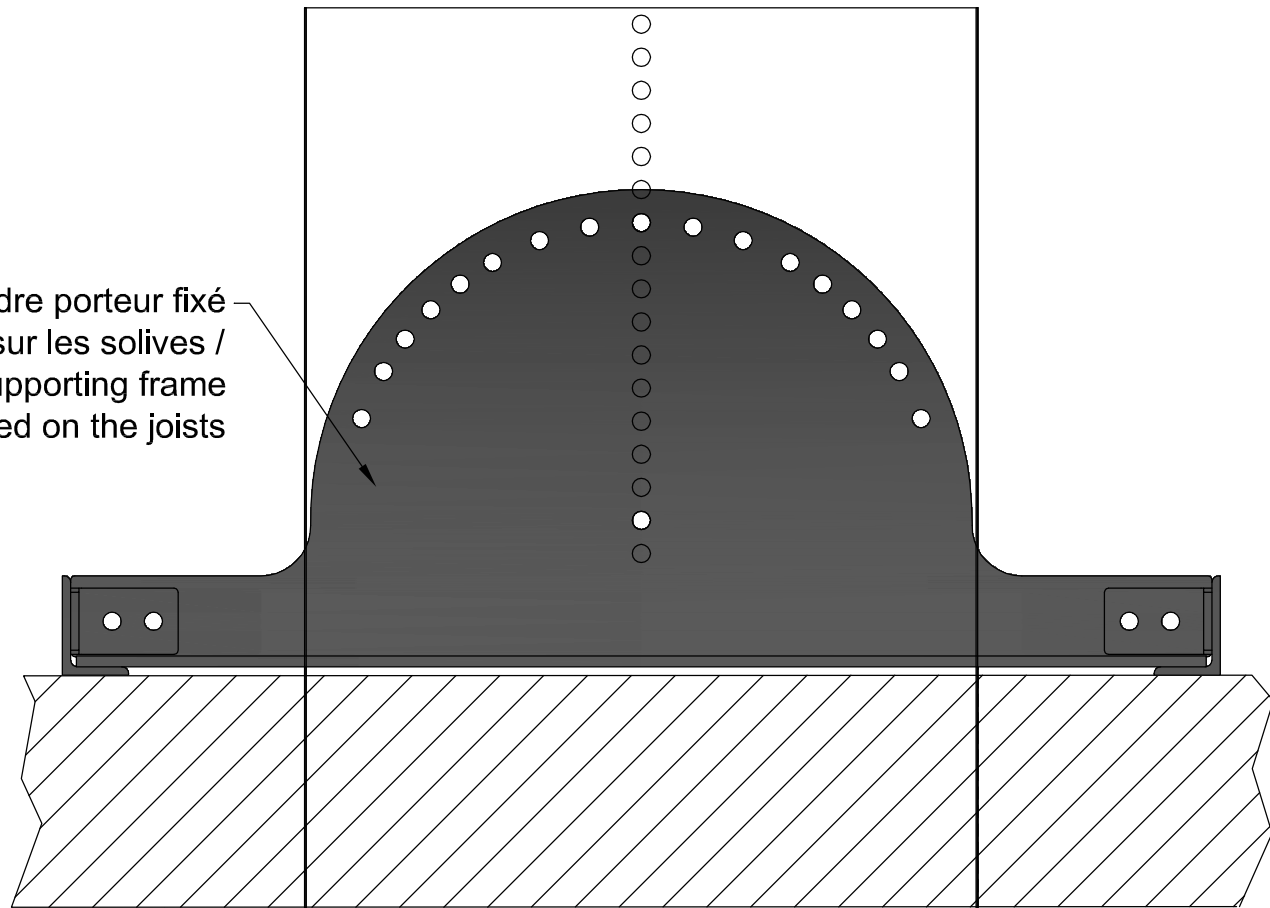

Solive /
Joist

Plafond /
Ceiling

4 vis #8 x 18mm (3/4")
Robertson autoperçreuse /
4 #8 x 18mm (3/4")
Robertson self-tapping
screws



6 x vis 6mm x 16mm
tête fraisée /
6 x 6mm x 16mm
countersunk screw



1/Plaque d'ancrage de
la cheminée à visser ici /
Chimney anchor plate
to be fastened here

2/Visser la plaque de support de la cheminée au
support de fixation Bordelet avec
les 6 vis de 6mm x 16mm fournies /
Fasten the chimney support plate to the Bordelet
Load Bearing Support with
the 6 included 6mm x 16mm screws

**Foyer- EVA 992 - Fireplace - raccordement plaque d'ancrage de
la cheminée - 254mm (10") - Chimney anchor plate connection**

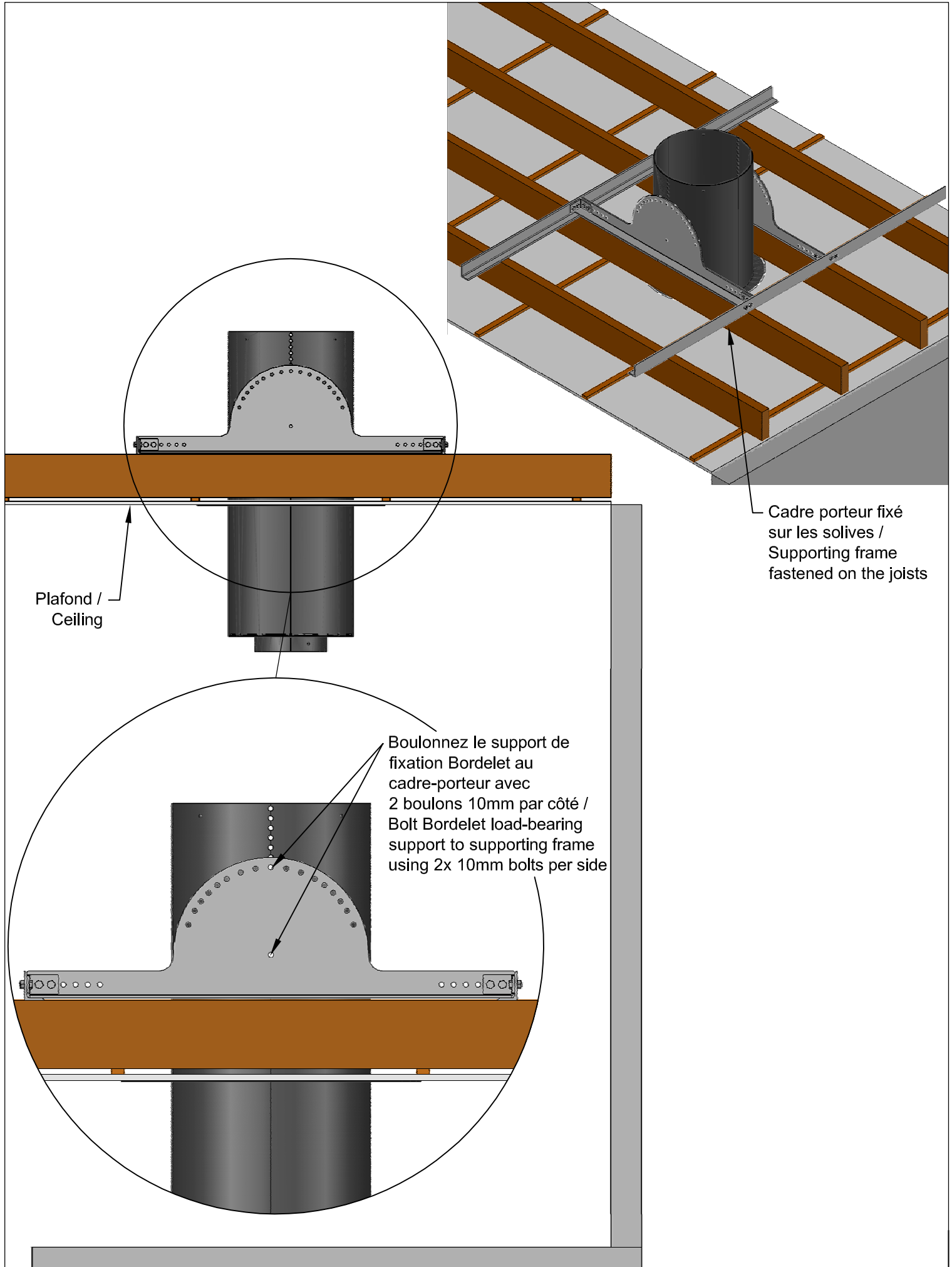

Matière: S235

Ep:

992 Fixation cadre porteur
plafond plat
Réf: 082

Date: 04/10/13

Indice: A

A4

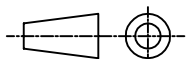

JC BORDELET
créateur d'harmonie

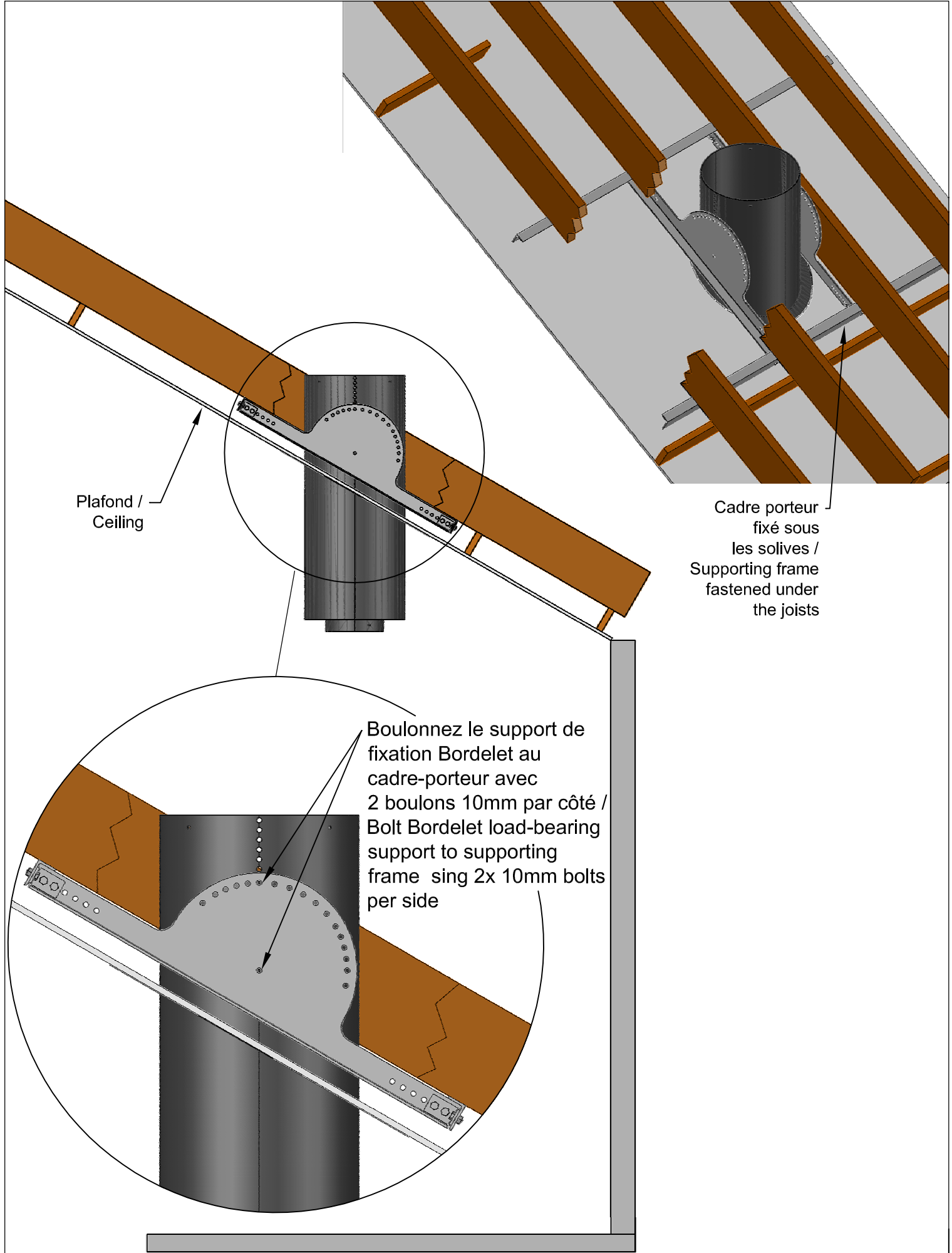

Plafond /
Ceiling

Cadre porteur
fixé sous
les solives /
Supporting frame
fastened under
the joists

Boulonnez le support de
fixation Bordelet au
cadre-porteur avec
2 boulons 10mm par côté /
Bolt Bordelet load-bearing
support to supporting
frame using 2x 10mm bolts
per side

Matière: S235

Ep:

992 Fixation cadre porteur
toit en pente / sloping roof
Réf: 083

Date: 04/10/13

Indice: A

A4

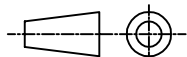

JC BORDELET
créateur d'harmonie

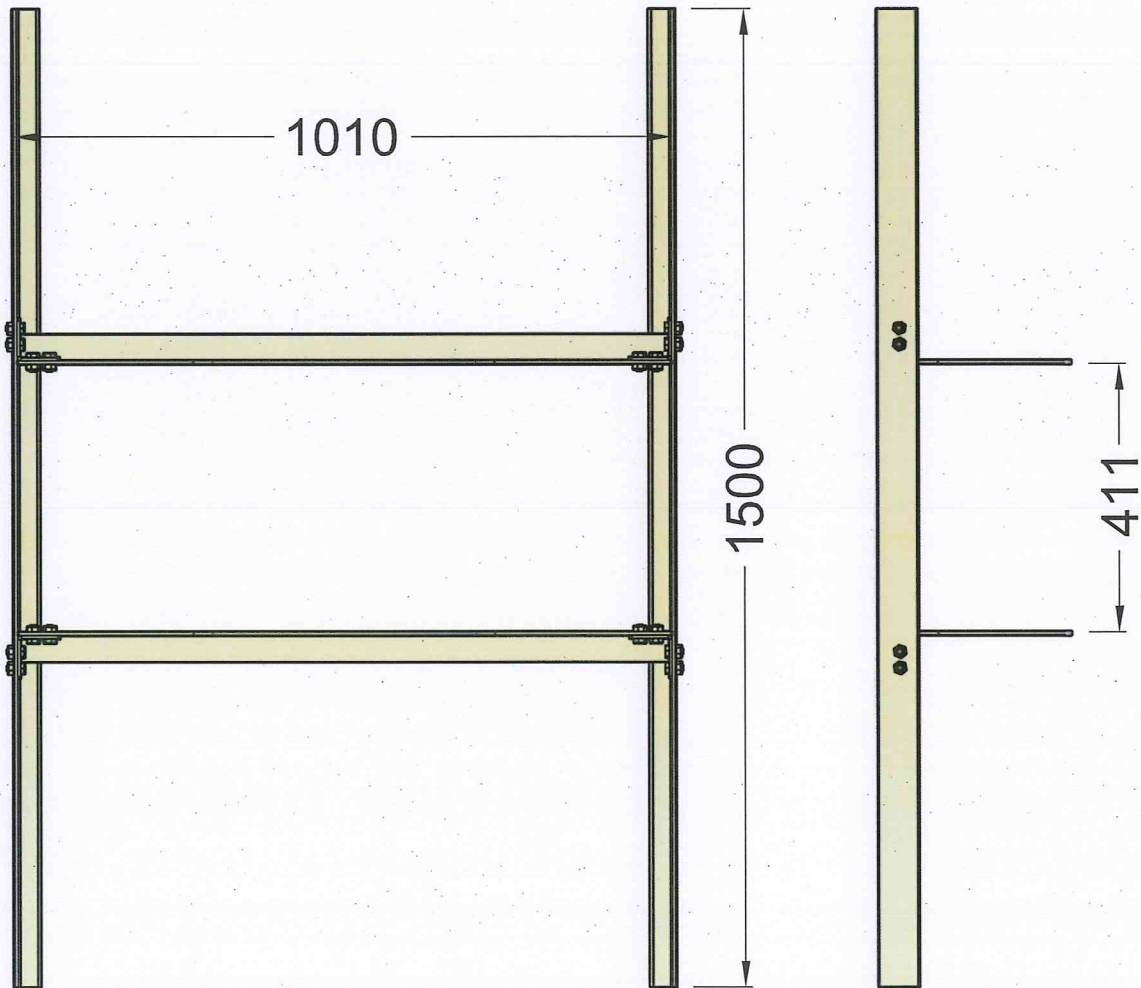
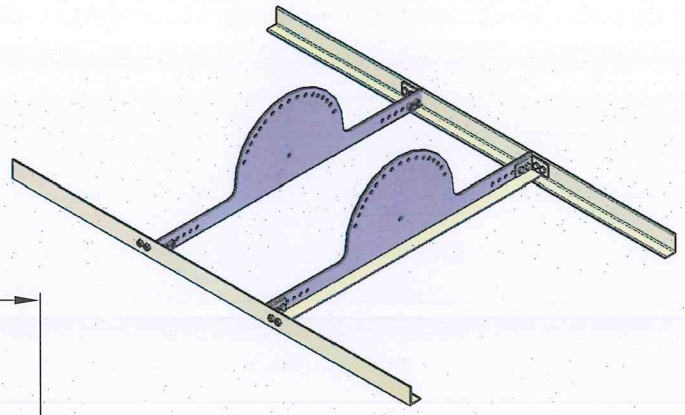
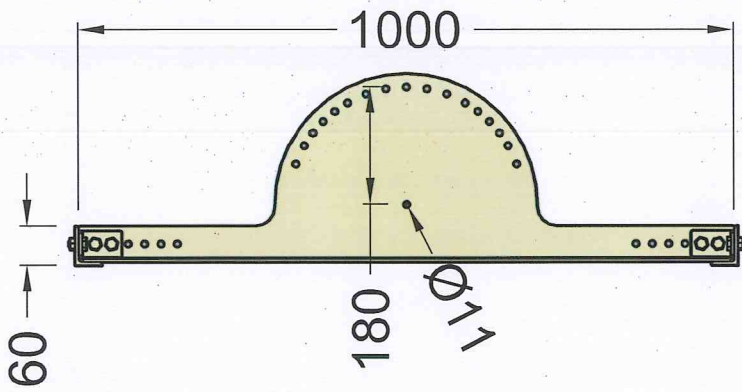

Matière: S235

Ep:

992 Cadre porteur

Date: 04/10/13

Indice: A

A4

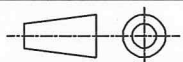

Réf: 081

JC BORDELET
créateur d'harmonie

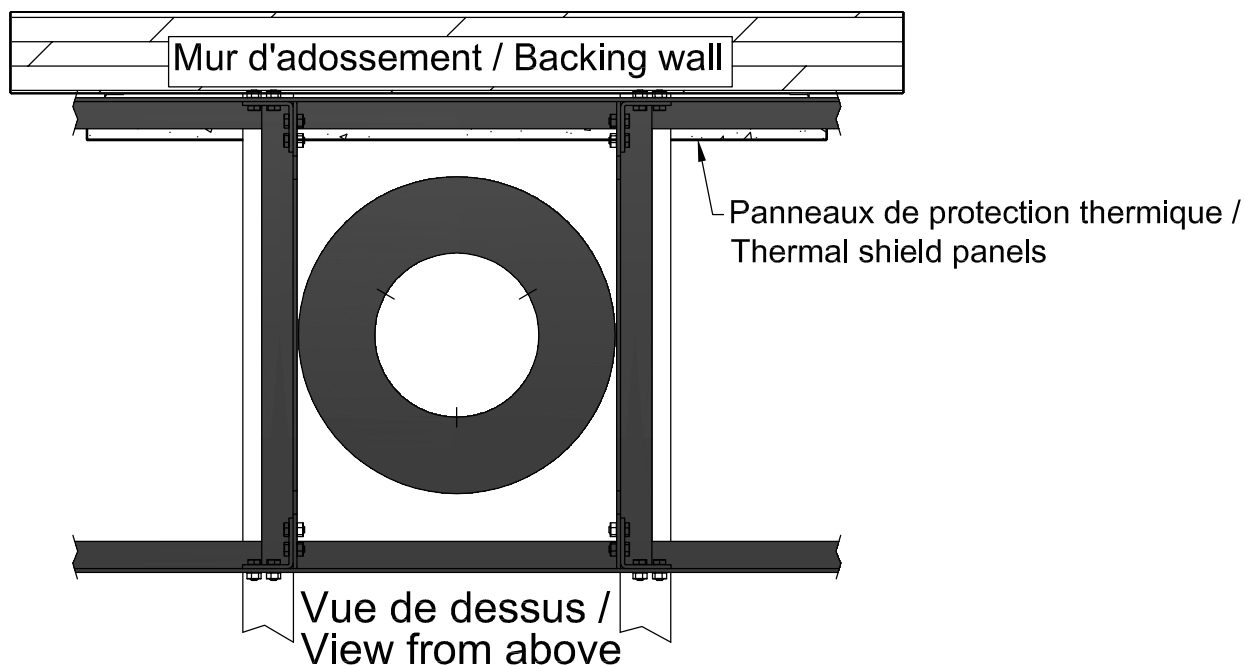
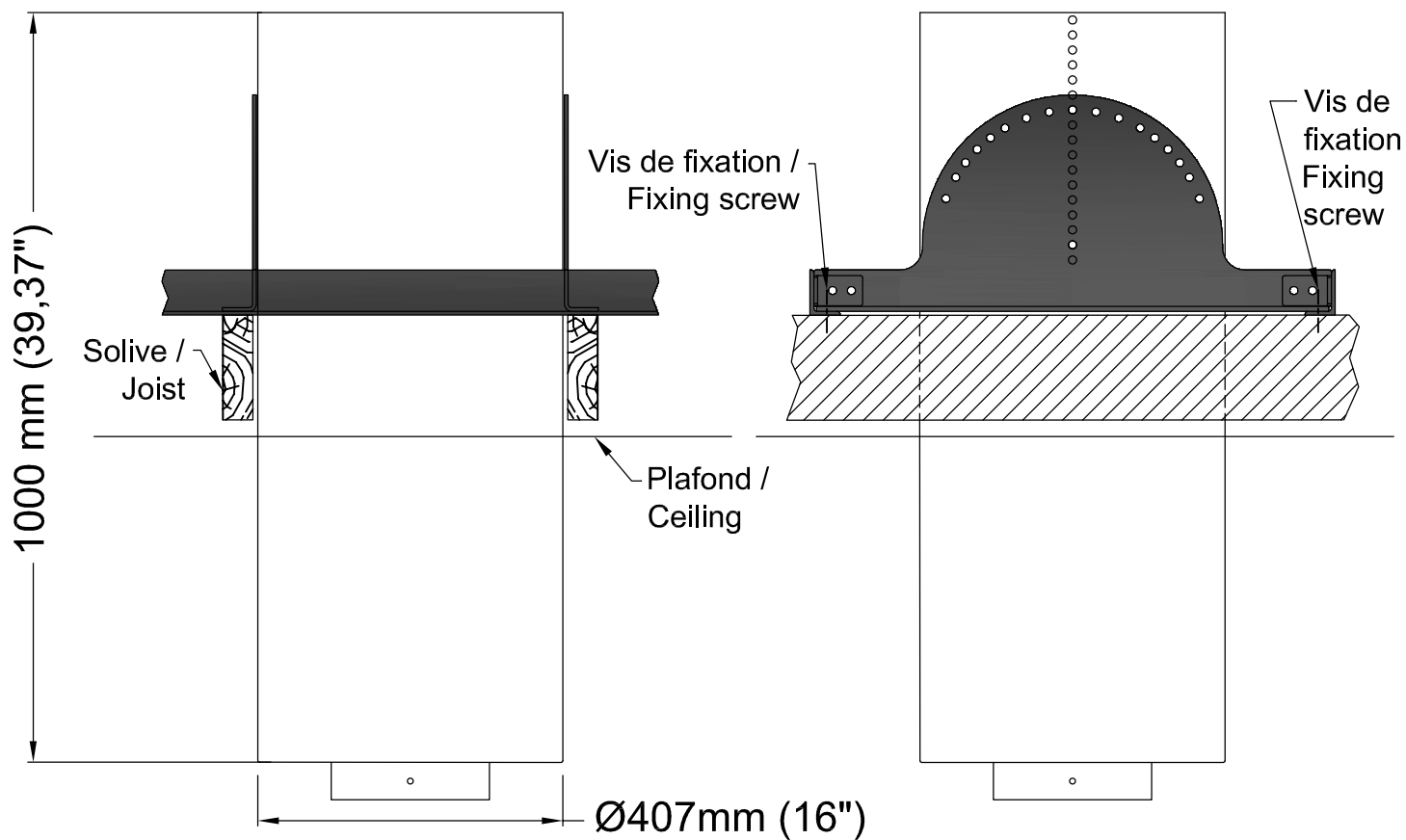

Foyer - EVA 992 - Fireplace - Caisson de fixation - Fixing piece

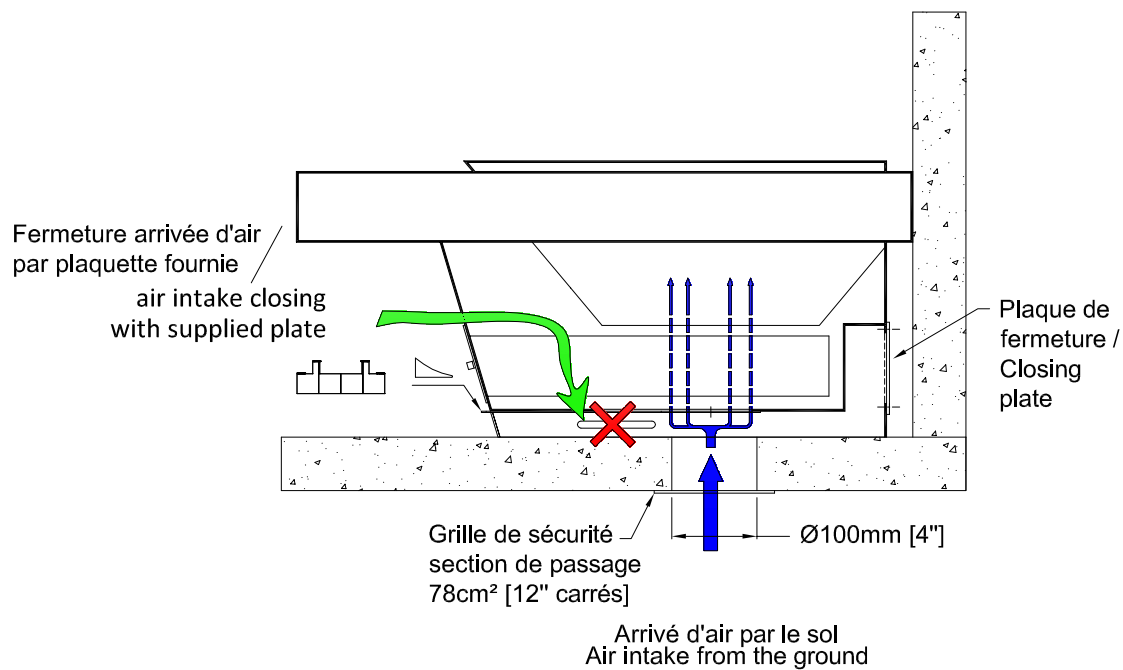
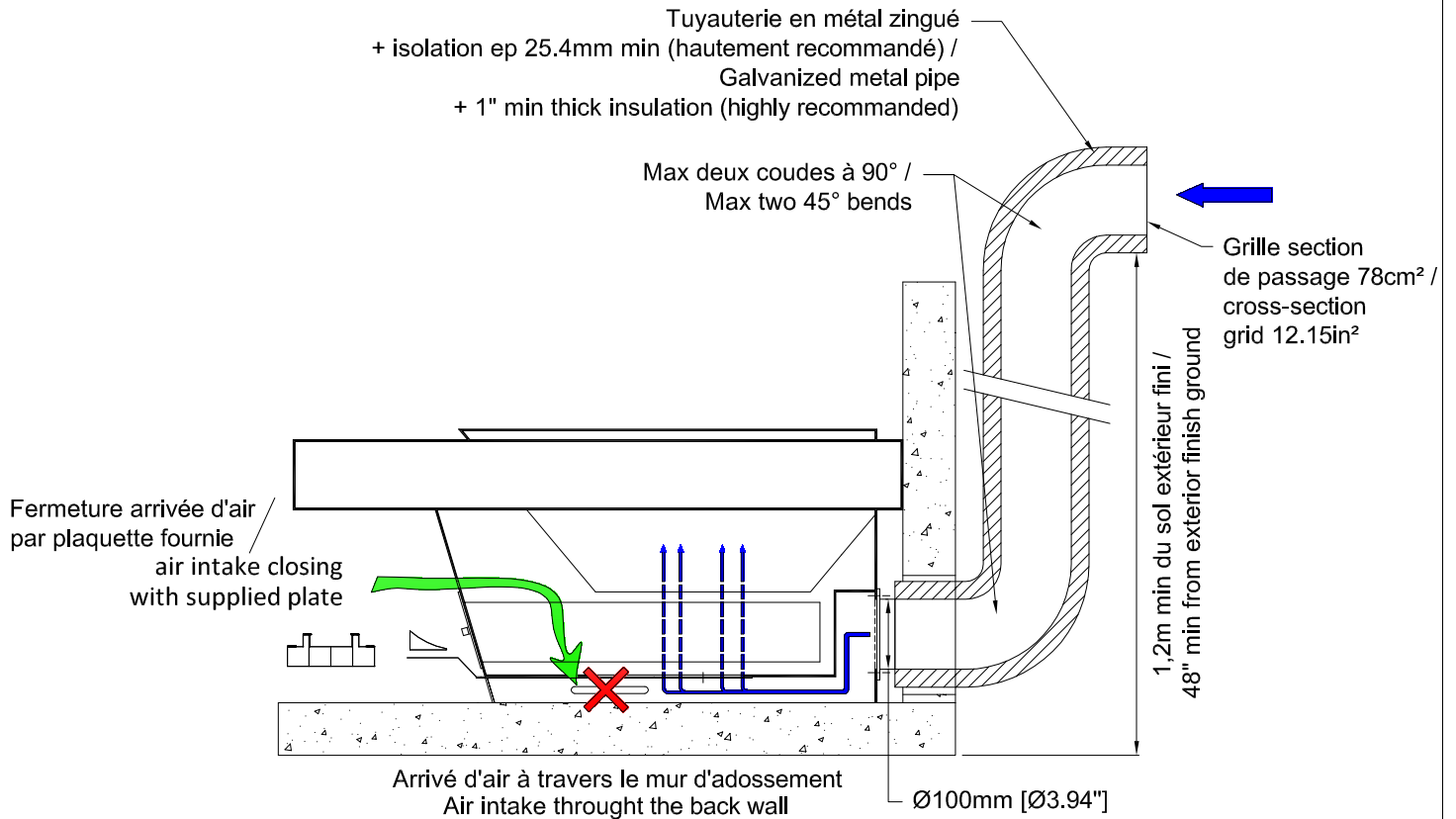

Longueur conduit arrivée d'air : 4m maximum
Air intake duct : 4.37yd maximum [4 m]

EVA 992 - Version out side air - Outside air version
Principe de connection - Connection principle

Renseignements à fournir:

- Type et dimensions du conduit de cheminée :

. Boisseaux : section intérieure :

. Si contre-tubage, dimensions :

. Conduits INOX : section intérieure et extérieure :

- Si conduit inox : marque :

- Espace arrière (distance de l'axe du conduit au mur d'adossement) : Droit :..... Gauche :.....

- Hauteur sous plafond (à l'axe si rampant) :

- Hauteur sous conduit (à l'axe si rampant) :

- Pente si plafond rampant :

- Type de plafond :

. Dalle béton :

. Dalle béton + faux plafond, fournir alors : distance **dessous** dalle / **dessous** plafond.....

. Fermettes + faux-plafond, fournir alors : distance **dessus** fermette / **dessous** plafond.....

- Y a-t-il une arrivée d'air au sol? diamètre?

Complétez ces renseignements par un croquis complet et lisible sur feuille blanche (carreaux à éviter)

Pour toutes précisions techniques, n'hésitez pas à nous consulter
ou vous référer aux normes de sécurité (DTU)

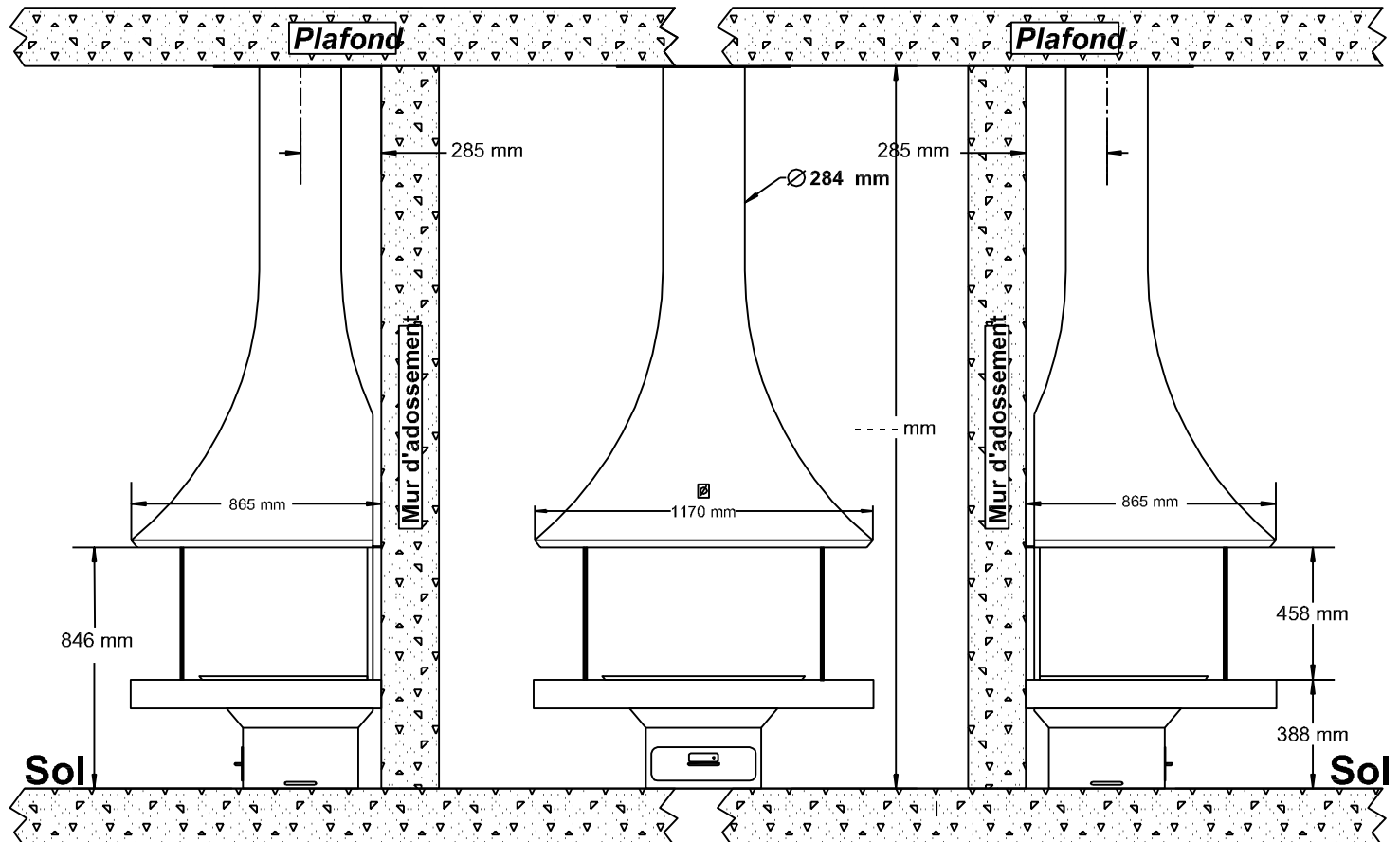

Date:16/12/09 | CB

JC Bordalet
INDUSTRIE

CHEMINEES BORDELET
Modèle : 992 Angle Foyer fermé

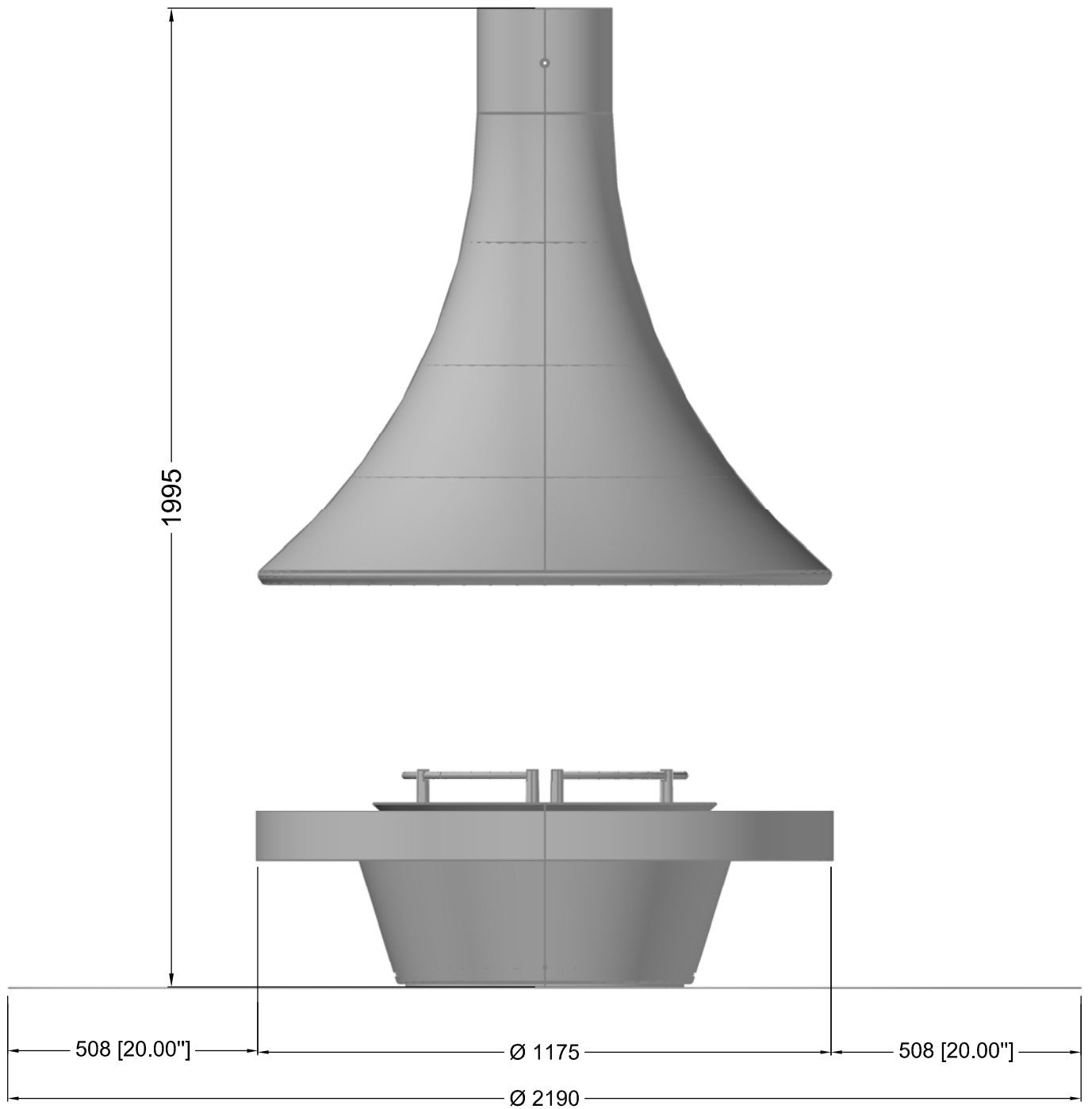

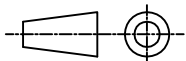
Matière:	Ep:	992 Ensemble cheminée Centrale ouverte Réf: 049	Date: 15/07/13	Indice: B
A4			JC BORDELET <small>créateur d'harmonie</small>	

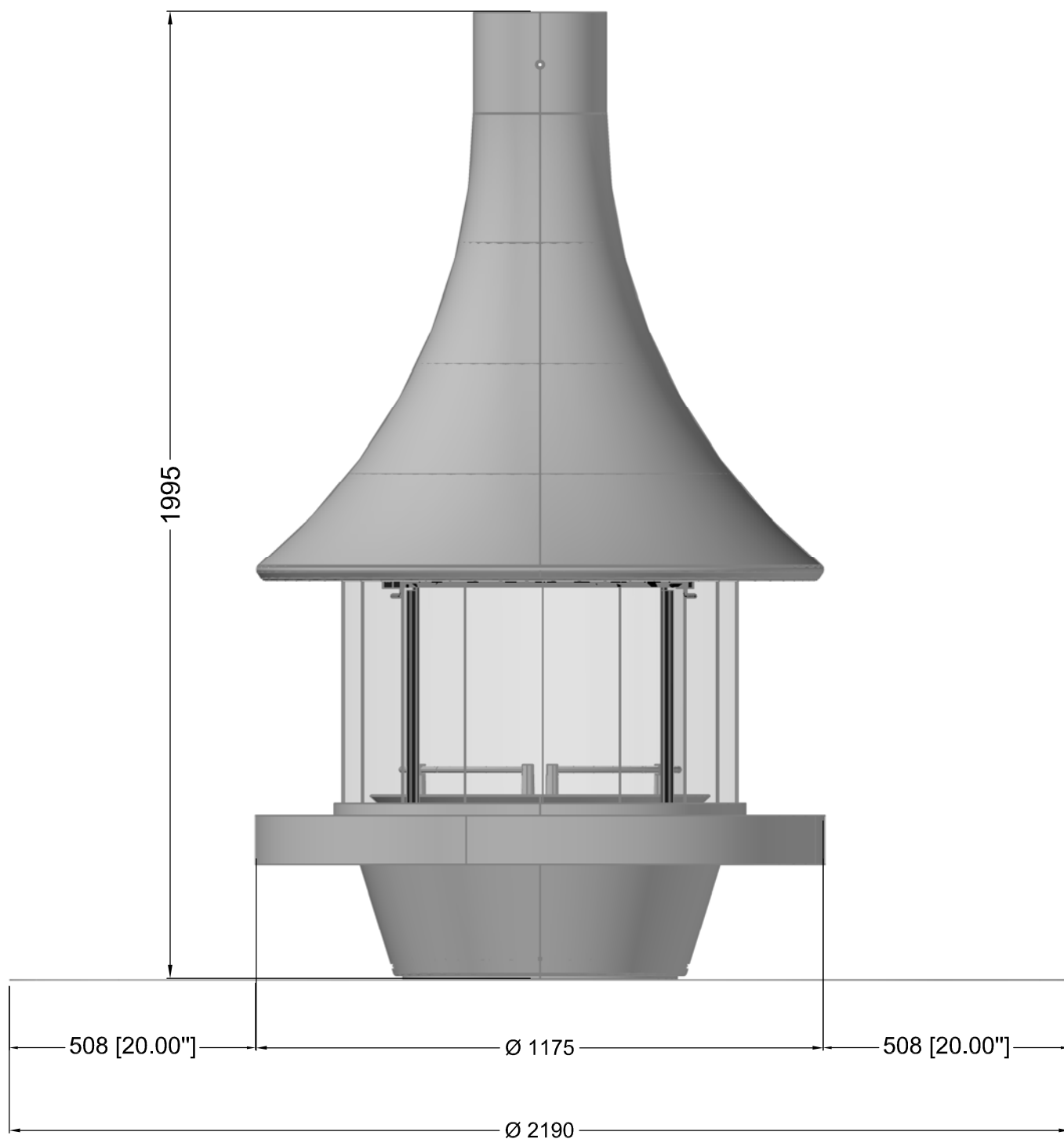

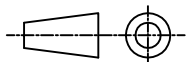
Matière:	Ep:	992 Ensemble cheminée Centrale vitrée Réf: 047	Date: 15/07/13	Indice: B
A4			JC BORDELET <small>créateur d'harmonie</small>	

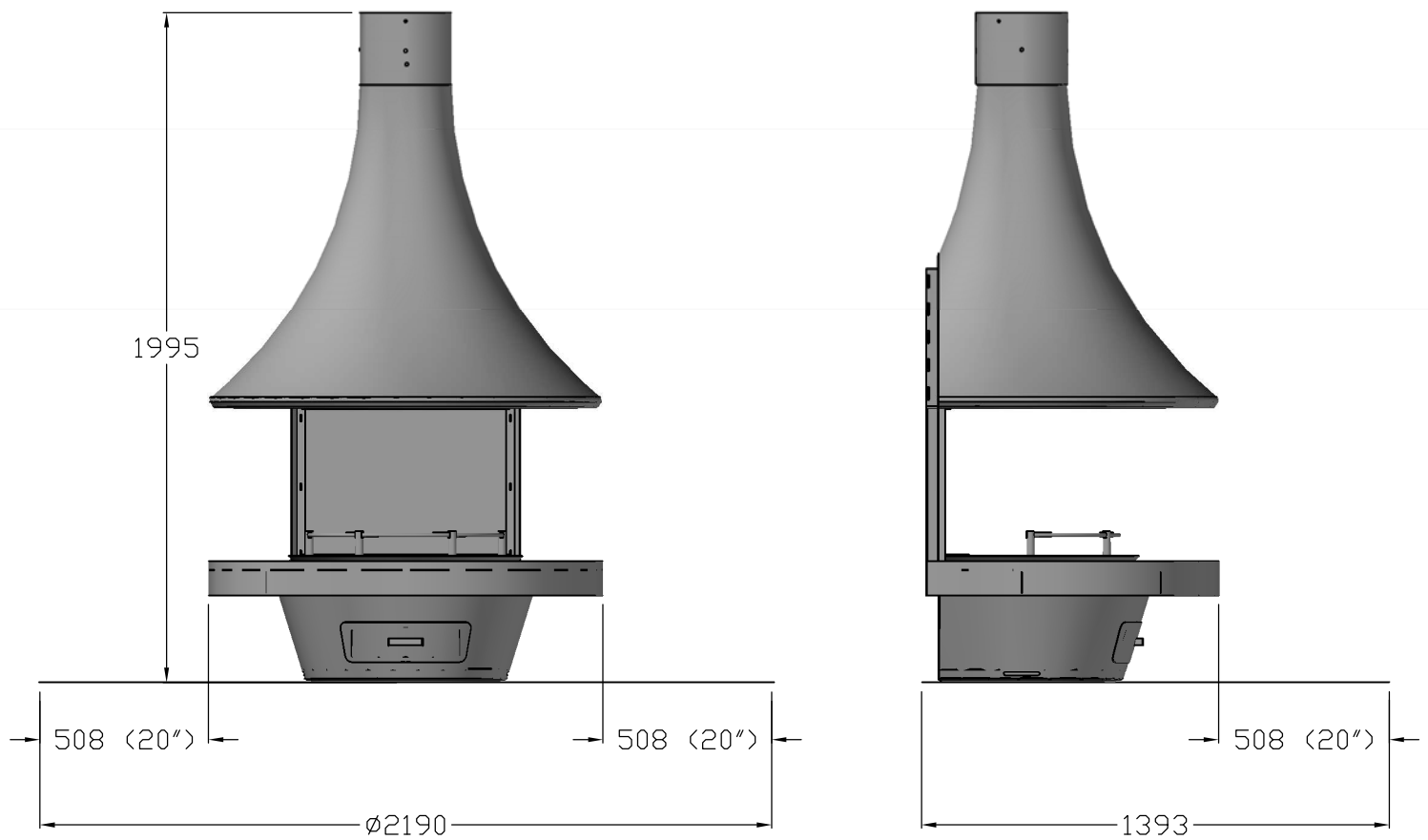

Matière:

A4

Ep:

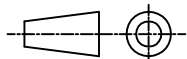

992 Ensemble cheminée
murale ouverte
Rèf : 048

Date: 09/07/13

Indice: B

JC BORDELET
créateur d'harmonie

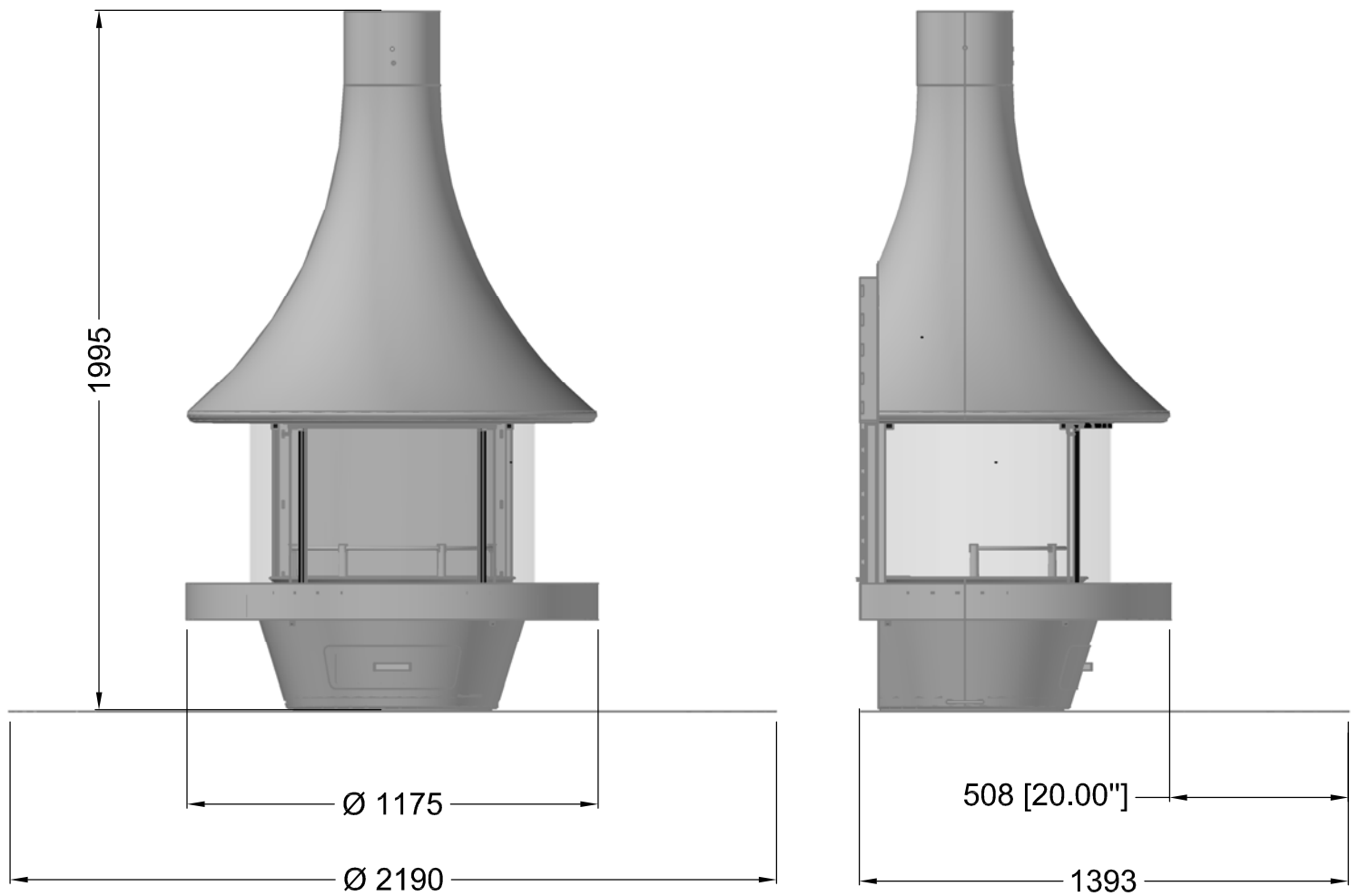

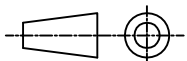
Matière:	Ep:	992 Ensemble cheminée Murale vitrée Réf: 046	Date: 15/07/13	Indice: B
A4			JC BORDELET <small>créateur d'harmonie</small>	

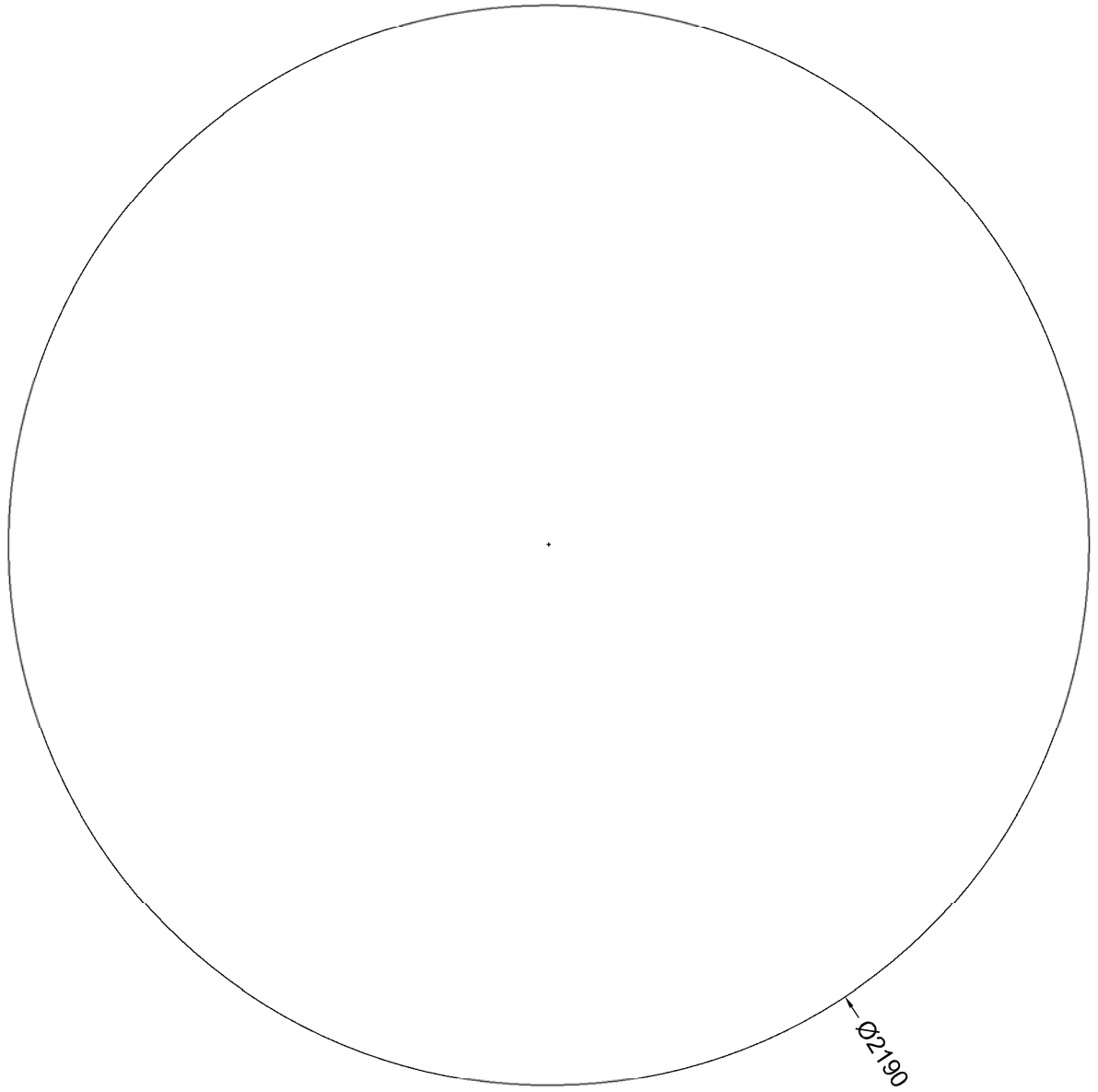

Matière:

Ep:

992 Centrale plaque de sol

Date: 09/07/13

Indice: A

A4

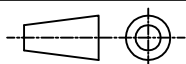

Réf: 098

JC BORDELET
créateur d'harmonie

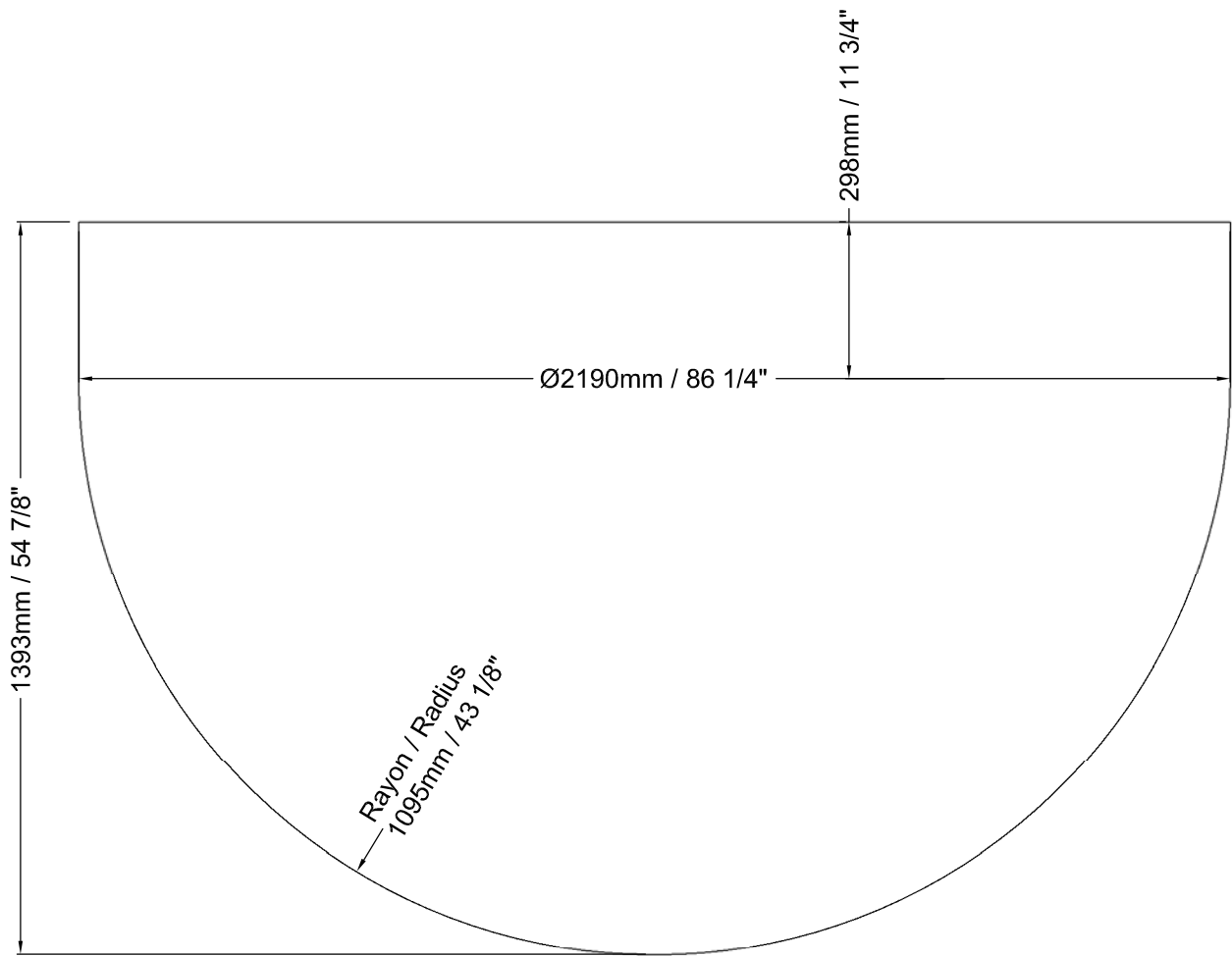

Matière:

Ep:

992 Murale plaque de sol

Date: 09/07/13

Indice: A

A4

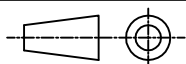

Réf: 097

JC BORDELET
créateur d'harmonie

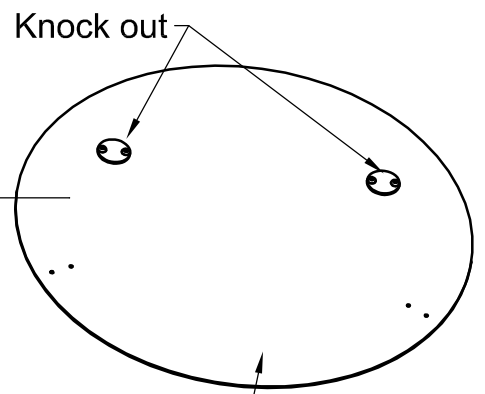
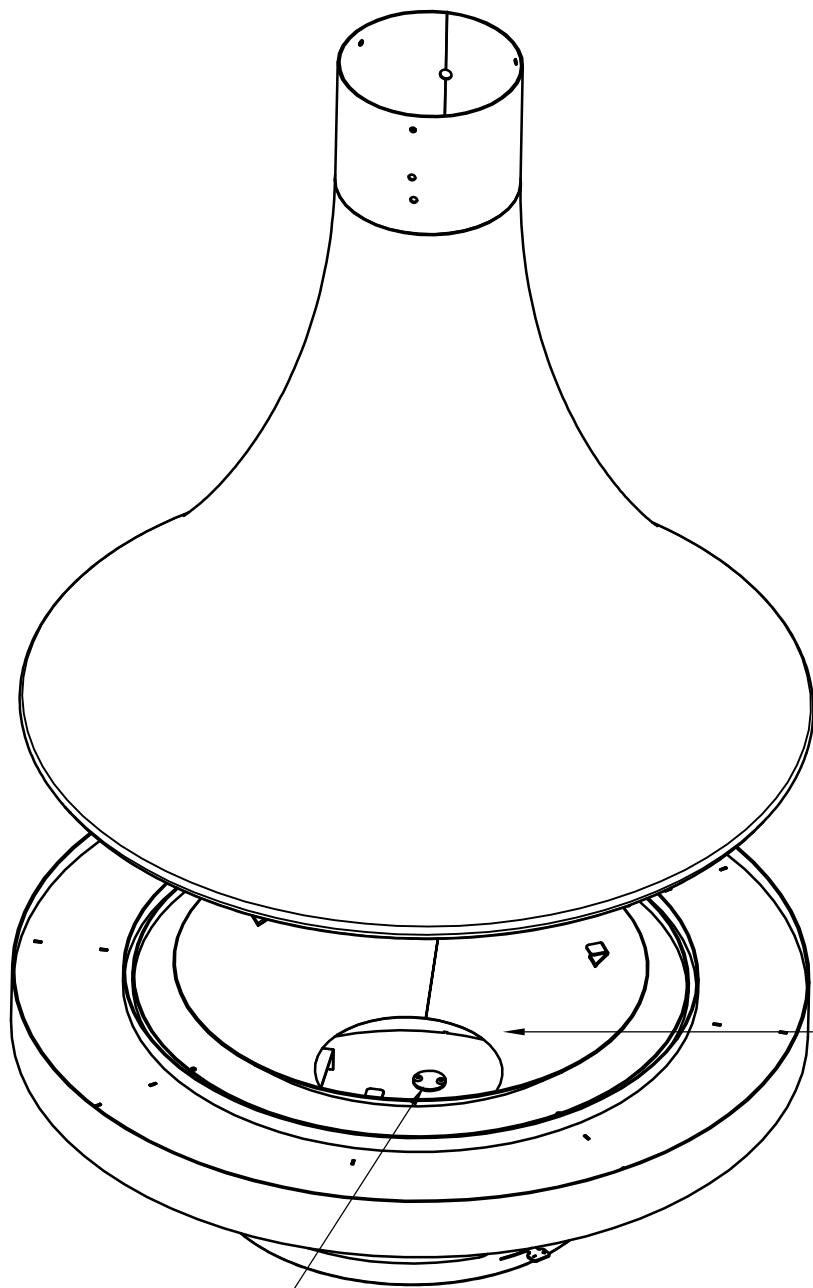

Knock out

Tôle spéciale bruleur gaz

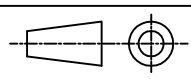
Matière:	Ep:	992 Central Position knock out Réf: 088	Date: 09/07/13	Indice: A
A4			JC BORDELET <small>créateur d'harmonie</small>	

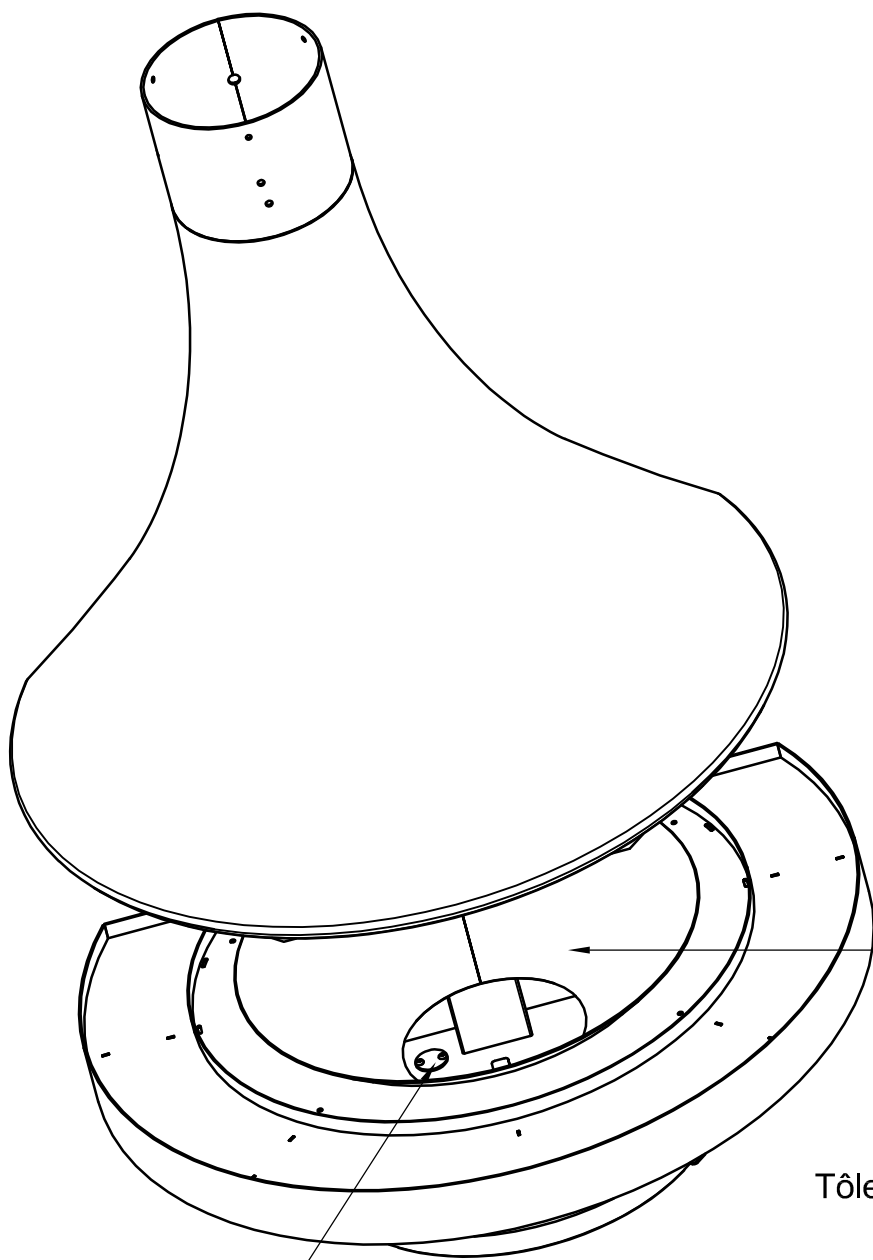

Knock out

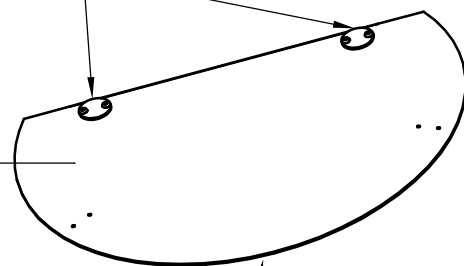

Tôle spéciale bruleur gaz

Knock out

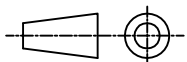
Matière:	Ep:	992 Mural Position knock out Réf: 087	Date: 09/07/13	Indice: A
A4			JC BORDELET <small>créateur d'harmonie</small>	

JC BORDELET

c r é a t e u r d ' h a r m o n i e

GARANTIE LIMITÉE

La garantie concerne exclusivement les vices de fabrication apparaissant sur le matériel postérieurement à la sortie du dépôt du revendeur.

Sont garantis :

PENDANT 5 ANS - Tous les composants incorporés dans la cheminée.

PENDANT 1 AN - Grille de cendrier / Déflecteur / Intérieur de foyers en briquettes réfractaires.

Les joints d'étanchéité de porte ne sont pas garantis.

EXCLUSIONS

N'est pas garantie la glace vitrocéramique conçue pour résister jusqu'à 750°C alors que la chaleur du foyer ne peut excéder 400°C. De ce fait, tout bris de glace ne peut résulter que d'un mauvais montage, d'un choc ou d'une mauvaise utilisation de l'appareil (exemple : mise en œuvre d'un autre combustible que le bois).

Sont exclus de la garantie du constructeur tous les défauts ou vices résultant d'un mauvais entretien, d'une mauvaise manipulation ou de réparations mal faites ou inappropriées. Sont également exclus de la garantie tout appareil ou accessoire non fourni par **BORDELET INDUSTRIE** ayant été ajouté ou adapté à ses fabrications.

La garantie ne couvre pas les dommages résultant de chocs, ni ceux découlant d'un mauvais montage, vice de pose ou d'une mauvaise utilisation de l'appareil. Comme tous les appareils de chauffage, l'air salé d'une région côtière, ou un environnement de haute humidité peuvent apporter une certaine oxydation à l'intérieur du foyer, notamment en cas d'utilisation épisodique (ex : résidences secondaires). De plus ceci peut avoir pour effet à terme d'endommager partiellement votre cheminée. Cette garantie n'est donc pas valable pour les dommages provenant de ces causes.

BORDELET INDUSTRIE n'est en aucun cas responsable pour tout dommage indirect ou provenant d'un accident de manipulation.

JC BORDELET

c r é a t e u r d ' h a r m o n i e

LIMITED WARRANTY

The warranty exclusively covers manufacturing defects appearing after delivery of goods from the distributor's warehouse.

The warranty covers:

FOR 5 YEARS – Every component included in the chimney.

FOR 1 YEAR – Ash grill / Deflector / Fireplace interior made of refractory bricks.

Door gaskets are not covered by the warranty.

EXCLUSIONS

The ceramic glass is not covered by the warranty as it is resistant to 750°C and the fireplace heat cannot exceed 400°C. Thus, any glass breakage can only result from wrong assembly, shock or inappropriate use of the appliance (example: using other fuel than cord wood).

Are excluded from the warranty any defects or flaws resulting from poor maintenance, bad handling or bad or inappropriate repairs. Also excluded for the warranty are appliances or accessories not supplied by **BORDELET INDUSTRIE** which have been added or adapted to its units.

The warranty does not cover damages resulting from shock nor those coming from wrong assembly, wrong installation or use of the appliance. Like every heating appliance, salt air from coastal regions or a very humid environment can bring some oxidation (rust) to the inside of the fireplace, especially in case of occasional use (ex : secondary residences). This can also lead to partial damages to the chimney conduit. Thus this warranty is not valid for damages resulting from these causes.

BORDELET INDUSTRIE is in any case not responsible for any indirect damages or coming from a handling accident.

JC BORDELET

c r é a t e u r d ' h a r m o n i e



www.powrmatic.ca